

Professional Bridge Tap Specifications

- **Winged handles** giving fingertip control
- **Nostalgic design**
- **Ideal for Farmhouse Style**
- **Taps can be situated in worktop**
- **Variable 'cranked feet design'**
- **Fully guaranteed with nationwide servicing***

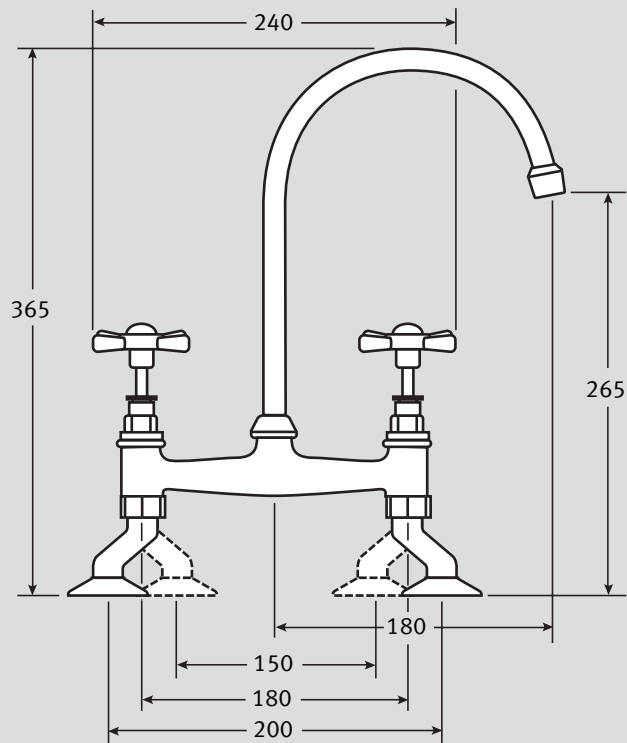

Material:	Solid brass body and brass spout and fittings
Type:	Twin tap hole Compression valve bridge mixer
Spout:	Tubular spout with screw down collar
Tails:	Cranked tails with nuts supplied
Tap Height:	265 (overall tap height 365)
Spout Reach:	180
Handle Width:	240
Colours:	Chrome or Gold
Maximum Water Pressure:	75 PSI (5 bar)
Maximum Hot-Water Temperature:	70°C
Recommended Hot-Water Temperature:	65°C
Guarantee:-	Valve: 5 year Surfaces: 1 year
Joints:	It is recommended that compression fittings are used to link the tap to the supply.

Tails:

N.B. Supplied with 90mm tails.

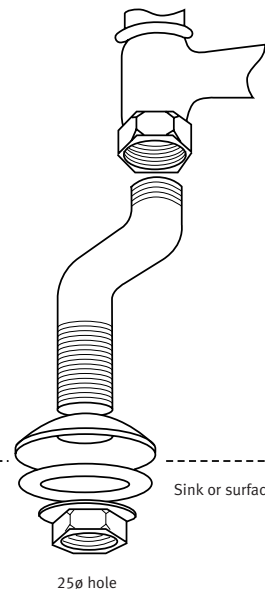

Valve Mechanism:

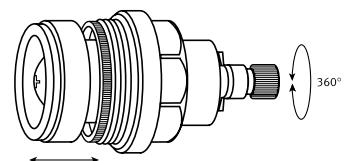

* Central Services: 01782 599258 All Franke taps are designed to conform with Water Research Council Requirements.

NB. Ceramic disc taps in certain installations or where there is a low head of water (below 4 metres) may not provide adequate flow rates. You are advised to check with your supplier.